

# **Indoor PM2.5 / PM10 / CO<sub>2</sub> / Temperature / Humidity 5-In-1 Detection Sensor**

## **Model: WH45**

### **Contents**

1. Introduction.....	2
2. Unpacking.....	2
3. Features .....	3
4. Sensor Set Up.....	5
5. Sensor Installation.....	7
6. Wi-Fi Configure with gateway.....	9
6.1 Pair with Gateway.....	9
6.2 Wi-Fi Connection for the Gateway .....	10
7. View Online Data on WS View .....	10
8. Appendix .....	12
9. Sensor Calibration.....	15
10. Specification.....	17

# 1. Introduction

Thanks for your purchasing of this integrated multifunction indoor air quality monitoring sensor. It measures PM2.5 / PM10 / CO2 / Temperature / Humidity. To ensure the best product performance, please read this manual and retain it for future reference.

# 2. Unpacking

Open your box and inspect that the contents are intact (nothing broken) and complete (nothing missing). Inside you should find the following:

<b>QTY</b>	<b>Item Description</b>
1	Particle Detection Sensor (PM2.5 / PM10 / /CO2 / Temperature / Humidity 5-In-1)
1	USB Cable
1	User Manual

**Table: Package content**

If any component is missing from the package, or broken, please contact our Customer Service department to resolve the issue.

## 3. Features

### Particle Detection Sensor

- Measures indoor PM2.5, PM10, CO<sub>2</sub> concentration, Temperature and Humidity every 60 seconds. USB connection for indoor use only
- CO2 value calibration function available on the device
- PM2.5 value Calibration function available when paired with GW1000/HP2551/HP3500/HP3501
- Long wireless range, up to 300 feet (100 meters) in open areas

### When paired with a GW1000 Wi-Fi Gateway:

- Monitor live sensor data on the Live Data page of the WS View app (requires the gateway and your phone using the same Wi-Fi network)

- Displays current PM2.5 / PM10 concentration/AQI and 24H AQI and air quality level index on the Live Data page of the WS View app
- Displays current CO<sub>2</sub> concentration and 24H average CO<sub>2</sub> concentration on the Live Data page of the WS View app
- Displays temperature and humidity data where the sensor located
- Calibration function available for PM2.5 value

**When paired with a Weather Station Console (HP2551/HP3500/HP3501):**

- The PM2.5, PM10 and CO<sub>2</sub> data automatically scrolls displaying on the screen every 5 seconds
- Calibration function available for PM2.5 value

**When uploaded to Ecowitt Weather Server:**

- View current sensor data & history records & graph on the website

- Set and receive email alerts from the server
- Remote monitoring with smart phone, laptop, or computer by visiting the website

## 4. Sensor Set Up

1. Remove the battery door on the base of the air quality sensor as shown in Figure 1

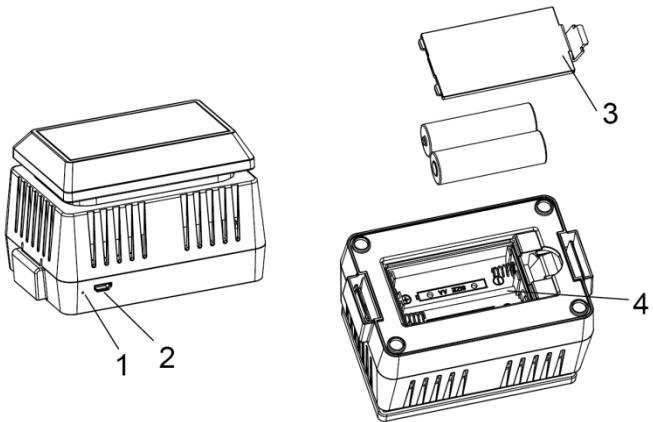

**Figure 1**

No	Description	No	Description
1	Red LED Indicator (RF transmission)	3	Battery Compartment Cover
2	AC Adapter USB Power Port	4	Battery Compartment

2. Insert two AA batteries and close the battery door.
3. Connect the USB cable between the sensor and an AC adapter(not included).

Note: After inserting the batteries or connecting AC power, the sensor LED indicator will light for 3 seconds – flash once after 20s , and then flash once per 1 minute thereafter. Each time it flashes, the sensor is transmitting data.

Note: The batteries (not included) are mainly for backup purpose. If only using battery power, alkaline batteries can only last for 2-3 days.

## 5. Sensor Installation

Before install the sensor into its permanent location, you may go to Section 6 to configure with the gateway first. Once the sensor has been confirmed working correctly, then you can go back here.

Place the sensor on a horizontally surface. Note that the vents must be clear of any obstructions, and we recommend placement away from other electronic devices to prevent interference. Do not place on a metal table to prevent RF signal loss.

**Note: This sensor is designed for indoor use only.**

Wireless communication is susceptible to interference, distance, walls and metal barriers. We recommend the following best practices for trouble free wireless communication.

1. Electro-Magnetic Interference (EMI). Keep the console several feet away from computer monitors and TVs.

2. Radio Frequency Interference (RFI). If you have other devices using the same RF frequency and communication is intermittent, try turning off these other devices for troubleshooting purposes. You may need to relocate the transmitters or receivers to avoid intermittent communication.

3. Line of Sight Rating. This device is rated at 300feet line of sight (no interference, barriers or walls) but typically you will get 100feet maximum under most real-world installations, which include passing through barriers or walls.

4. Metal Barriers. Radio frequency will not pass through metal barriers such as aluminum siding. If you have metal siding, align the remote and console through a window to get a clear line of sight.



## **6. Wi-Fi Configure with gateway**

This Particle Detection Sensor doesn't have a display function and you need to use our WS View App to view the data on your mobile application after pairing this device with our GW1000 Wi-Fi Gateway or HP2551/HP3500/HP3501/WH0295 console (all sold separately).

### **6.1 Pair with Gateway**

If GW1000 has been in operation, and you have never had any WH45 sensor setup before, just power up the sensor and GW1000 will pick sensor data automatically.

If a WH45 sensor has been hooked on GW1000 before, and you have a new sensor to replace the old one, just power off the old sensor and power on the new sensor, open the APP: WS View, tap the device and go to sensor ID page, locate the WH45 sensor, select "Register", then the gateway will erase the previous registered sensor and have the new sensor paired.

## 6.2 Wi-Fi Connection for the Gateway

For this part, please refer to the manual of the GW1000 Wi-Fi gateway.

Any question, please contact the customer service.

## 7. View Online Data on WS View

When the Wi-Fi configuration is done, you can view the live data of your sensor on the WS View application.

Device List		Live Data		More	
GW1000B-WIFI38B4					
Indoor Temperature		Indoor Humidity			
30.1 °C		71 %			
Absolute Pressure		Relative Pressure			
992.3 hPa		992.3 hPa			
Temperature		CO2		Humidity <span>DC</span>	
32.5 °C				63 %	
PM2.5	Real-time AQI	24H AQI			
1.6 ug/m <sup>3</sup>	7 Good	21 Good			
PM10	Real-time AQI	24H AQI			
2.3 ug/m <sup>3</sup>	2 Good	6 Good			
CO2		24H CO2			
463 ppm		507 ppm			
GW1000B_V1.6.3					

Note:

The WH45 sensor data can be only viewed on the Live Data interface since it doesn't support uploads to weather underground.

If you choose to upload the data to our weather server: <https://www.ecowitt.net>, you can view the live data/history graph and download the records on the website. You can add a shortcut of the website on the home screen of your phone for quick access.

## 8. Appendix

### Air Quality Index (AQI) for the PM2.5 Concentration (24hr)

<b>AQI</b>	<b>Air Pollution Level</b>	<b>PM2.5 Concentration ug/m<sup>3</sup></b>
0 - 50	Good	0.0-12.0
51 -100	Moderate	12.1-35.4
101-150	Poor	35.5-55.4
151-200	Unhealthy	55.5-150.4
201-300	Severe	150.5-250.4
300+	Hazardous	250.5+

## **Air Quality Index (AQI) for the PM10 Concentration (24hr)**

<b>AQI</b>	<b>Air Pollution Level</b>	<b>PM2.5 Concentration ug/m3</b>
0 - 50	Good	0-54
51 -100	Moderate	55-154
101-150	Poor	155-254
151-200	Unhealthy	255-354
201-300	Severe	355-424
300+	Hazardous	425+

Carbon Dioxide Levels and potential health problems are indicated below:

- 250-350 ppm: background (normal) outdoor air level
- 350-1,000 ppm: typical level found in occupied spaces with good air exchange

- 1,000-2,000 ppm: level associated with complaints of drowsiness and poor air
- 2,000-5,000 ppm: level associated with headaches, sleepiness, and stagnant, stale, stuffy air; poor concentration, loss of attention, increased heart rate and slight nausea may also be present.
- >5,000 ppm: This indicates unusual air conditions where high levels of other gases also could be present. Toxicity or oxygen deprivation could occur. This is the permissible exposure limit for daily workplace exposures.
- >40,000 ppm: This level is immediately harmful due to oxygen deprivation.

Reference link:

<https://ohsonline.com/Articles/2016/04/01/Carbon-Dioxide-Detection-and-Indoor-Air-Quality-Control.aspx?Page=2>

## 9. Sensor Calibration

CO<sub>2</sub>: There is an easy way to find the CO<sub>2</sub> sensor is drifted or not: put the sensor in outdoor open air locations, away from any combustion exhausts, wait for 30 minutes, you should see the CO<sub>2</sub> reading is 420ppm +/-10. If it is far from this reading, you can wait for some more time, and test it during night to confirm. Once it is confirmed, you can open the back housing, and use a clipper pin to press the Calibrate button as below figure shows, leave it for 4minutes at least, because the calibration must be completed in a ventilated environment with Co<sub>2</sub> fluctuations  $< \pm 15$ ppm for 4 minutes, and the calibration will always be in the state if the conditions are not met. If the led flash, it indicates that calibration is not finished.

Note: When the CO<sub>2</sub> sensor in calibration state, please do not stand near the sensor, otherwise it will affect the calibration result.

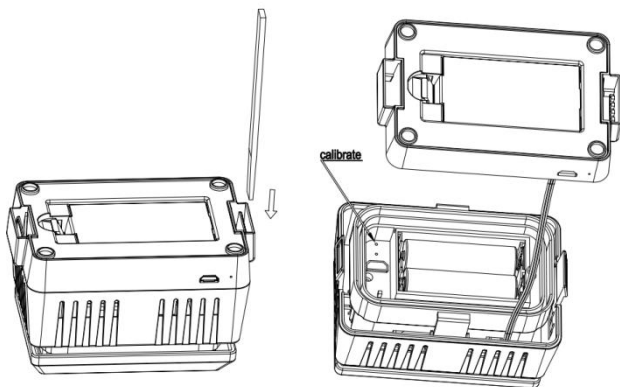

PM2.5/PM10: It is not possible to calibrate on the sensor side, and you can calibrate through WS View App when paired with GW1000 or on the console when paired with HP2551/HP3500/HP3501, which saves the offset value on the gateway side before sending data to [www.ecowitt.net](http://www.ecowitt.net) server. However if PM2.5 data is persistently low, it can be that there is a spider net going inside the sensor. So please clean the sensor from time to time to see if there is any sign of spider penetration.

Note: If the battery level is lower than 4 bars, calibration is prohibited. When the led light on the sensor is steady



for 3 seconds, it indicates that calibration is prohibited.

## 10. Specification

Measurement	Range	Accuracy	Resolution
PM 2.5	0~999ug/m <sup>3</sup>	>100ug/m <sup>3</sup> , ±15% <100ug/m <sup>3</sup> , ±15ug/m <sup>3</sup>	1ug/m <sup>3</sup>
PM 10	0~999ug/m <sup>3</sup>	>100ug/m <sup>3</sup> , ±25% <100ug/m <sup>3</sup> , ±25ug/m <sup>3</sup>	1ug/m <sup>3</sup>
CO <sub>2</sub>	0- 40000ppm	400- 10000ppm ±(30ppm ±3%)	1ppm
Temperature	-40 °C – 60 °C (-40 °F - 140 °F)	± 1 °C, or ± 2 °F	0.1 °C, or 0.1 °F
Humidity	0%~99%	± 5%	1%

Transmission distance in open field: 100m(300 feet)

Frequency: 433/868/915MHz (depending on location)

Sensor reporting interval: 1 minute

### **Power consumption**

- Particle Detection Sensor: AC power (5V 1A) - Not included  
2 x AA 1.5V Batteries for back up - Not included

Note:

If you have a WH41 or WH43 PM2.5 sensor, the reading of PM2.5 may be different due to different sensor type used.

Note:

This device is mainly used to detect the particle concentration in air. The accuracy for temperature and humidity reading may vary due to different environment:

When the sensor is placed at unventilated environment, the temperature reading may be 2 degrees higher.

When the sensor is placed at ventilated environment, the temperature and humidity reading may be lower than the actual reading.